

DIRIS A14

Multifunction meter - MID



DIN rail mounted



Door mounted



1. DOCUMENTATION	3
2. HAZARDS AND WARNINGS	4
2.1. Risk of electrocution, burns or explosion	4
2.2. Risk of damaging the unit	4
2.3. Liability	4
3. PRELIMINARY OPERATIONS	5
4. INTRODUCTION	6
4.1. Introduction to the DIRIS A14	6
4.2. Functions	6
4.3. Front views	6
4.4. Dimensions	6
4.5. Electrical values measured	7
5. INSTALLATION	8
5.1. Recommendations and safety	8
5.2. DIN rail mounted	8
5.3. Door mounted	8
6. CONNECTION	9
6.1. DIRIS A14 connection - DIN rail mounted	9
6.2. DIRIS A14 connection - door mounted	9
6.3. Connection to the electrical network and to the loads	10
6.3.1. Configurable loads based on the network type	10
6.3.2. Description of the main network and load combinations	10
7. MID COMPLIANCE	12
8. COMMUNICATION	14
8.1. General information	14
8.2. RS485 rules	14
8.3. Communication structure	15
8.4. Communication tables	15
9. CONFIGURATION	16
9.1. Configuring using the screen	16
9.1.1. Example: configuring the choice of current transformer	17
9.1.2. Overall view of the programming menu	18
9.1.3. Detailed view of the programming menu	19
10. USE	20
10.1. Detailed view of the energy menu	21
10.2. Detailed view of the measurement menu	22
11. CONNECTION TEST FUNCTION	23
12. ASSISTANCE	24
13. CHARACTERISTICS	25
14. PERFORMANCE CLASSES	27
14.1. Specification of the characteristics	27
15. LIST OF ABBREVIATIONS	28

1. DOCUMENTATION

All documentation on the DIRIS A14 is available on the website at the following address:
www.socomec.com/en/diris-a14



2. HAZARDS AND WARNINGS

The term "device" used in the paragraphs below refers to the DIRIS A14.

The assembly, use, servicing and maintenance of this equipment must only be carried out by trained, qualified professionals. SOCOMEC shall not be held responsible for failure to comply with the instructions in this manual.

2.1. Risk of electrocution, burns or explosion

- This device must only be installed and serviced by qualified personnel who have in-depth knowledge of installing, commissioning and operating the device and who have had appropriate training. He or she should have read and understood the various safety measures and warnings stated in the instructions.
- Before working on the device, disconnect the voltage inputs and short circuit the secondary of each current transformer (SOCOMEC PTI).
- Always use an appropriate voltage detection device to confirm the absence of voltage.
- Replace all devices, doors and covers before turning on power to this equipment.
- Always power the device with the correct rated voltage.
- Install the unit following the recommended installation instructions and in a suitable electrical cabinet.

Failure to take these precautions could cause death or serious injuries.

2.2. Risk of damaging the unit

To ensure that the unit operates correctly, make sure that:

- The device is correctly installed.
- a maximum voltage at the voltage input terminals of 460 V AC phase-phase or 265 V AC phase-neutral
- The network frequency indicated on the product is observed: 50 or 60 Hz.
- a maximum current of 20 A on the current input terminals (I1, I2 and I3).

Failure to respect these precautions could cause damage to the unit.

2.3. Liability

- Assembly, connection and use must be carried out in accordance with the installation standards currently in force.
- The device must be installed in accordance with the rules given in this manual.
- Failure to observe the rules for installing this device may compromise the product's intrinsic protection.
- The device must be positioned within an installation which complies with the standards currently in force.
- Any cable which needs to be replaced may only be replaced with a cable having the correct rating.

3. PRELIMINARY OPERATIONS

To ensure the safety of personnel and the device, please carefully read the contents of these instructions before installation.

Check the following points as soon as you receive the package containing the unit:

- The packaging is in good condition,
- The device has not been damaged during transportation,
- The device reference number conforms to your order,
- The package includes:
 - 1 device
 - 1 sealing kit
 - 1 line resistor (ref. 4899 0019)
 - 1 Quick start

4. INTRODUCTION

4.1. Introduction to the DIRIS A14

The DIRIS A14 is a MID-certified multifunction meter suitable for monitoring and managing a network's electrical energy. The DIRIS A14 supplies voltage, current, power and energy measurements. Users can easily access all the product functionalities using the screen and the push buttons. It is fitted with an RS485 modbus communication bus. It can be mounted on a DIN rail (ref. 4825 0020) or fitted on a door (opening 92x92 mm) (ref. 4825 0021).

4.2. Functions

- Electrical parameter measurements: I, U, V, f
- Power, power factor
- Imported and exported active and reactive energy
- RS 485 modbus communication

Description	References
DIRIS A14 with RS485 modbus communication (DIN rail mounted)	4825 0020
DIRIS A14 with RS485 modbus communication (door mounted)	4825 0021

4.3. Front views

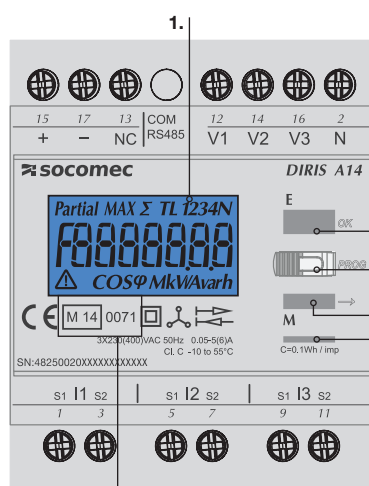

Ref. 4825 0020

1. Backlit LCD display
2. Access to energies and programming validation.
3. Access to programming menu.
4. Access to electrical parameters and power levels.
5. Metrological LED on active energy - 0.1Wh / impulse.
6. Information relating to MID certification.

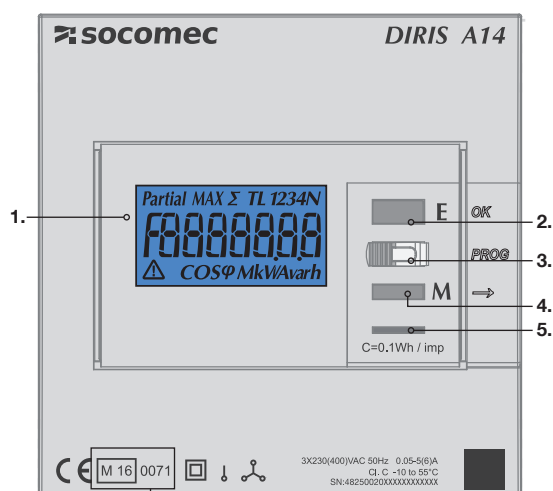

Ref. 4825 0021

4.4. Dimensions

Dimensions: in/mm

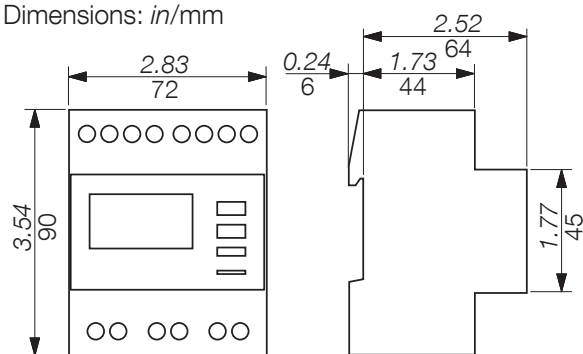

Ref. 4825 0020

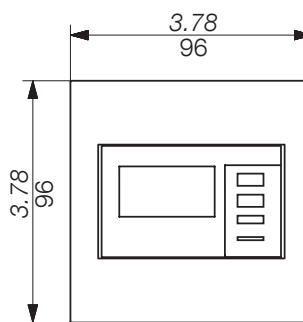

Ref. 4825 0021

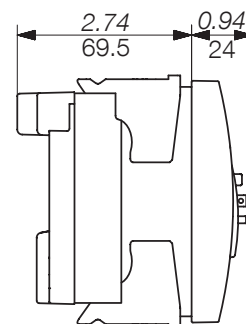

4.5. Electrical values measured

Three-phase dimension			LCD display	Via modbus communication
Active energy	consumed (Ea+)	total	total $\sum T_i$ with 10Wh resolution	kWh and 10Wh on T_i and total $\sum T_i$
		partial	total $\sum T_i$ with 10Wh resolution	kWh and 10Wh on T_i and total $\sum T_i$
	produced (Ea-)	total	resolution 10 Wh	kWh and 10Wh
		partial	resolution 10 Wh n.a.	kWh and 10Wh
Reactive energy	consumed (Er+)	total	resolution 10varh	kvarh and 10varh
		partial	resolution 10varh	kvarh and 10varh
	produced (Er-)	total	resolution 10varh	kvarh and 10varh
		partial	resolution 10varh	kvarh and 10varh
Active power	$\sum P_{+,-}$	three-phase	resolution 10W	kW and 10W
	$P_{i+,-}$	by phase	n.a.	kW and 10W
Reactive power	$\sum Q_{+,-}$	three-phase	resolution 10var	kvar and 10var
	$Q_{i+,-}$	by phase	n.a.	kvar and 10var
Apparent power	$\sum S$	three-phase	resolution 10VA	kVA and 10VA
	I_f	by phase	n.a.	kVA and 10VA
Power factor	$\sum PF_{+,-}$	three-phase	n.a.	1/1000
	$PF_{i+,-}$	by phase	n.a.	1/1000
Current	I_1, \dots, I_N	by phase	resolution 10mA	mA
Neutral voltage	V_1, \dots, V_3	phase-neutral	resolution 10mV	10mV
Phase to phase voltage	U_1, \dots, U_3	phase-phase	resolution 10mV	10mV
Frequency	f		resolution 10mHz	10mHz
Cos ϕ	Cos ϕ	three-phase	resolution 0.01	1/1000
	cos ϕ_i	by phase	n.a.	1/1000
Current distortion rate	THD I_1, \dots, I_3	by phase	n.a.	1/100 %
Voltage distortion rate	THD V_i, U_i	by phase	n.a.	1/100 %
Frequency	f		n.a.	1/100 of Hz
Max. current	Max. I_1, \dots, I_N	by phase	✓	✓
Max. active power	Max. $\sum P_+$	three-phase	✓	✓
Max. reactive power	Max. $\sum Q_+$	three-phase	✓	✓
Max. apparent power	Max $\sum S$	three-phase	✓	✓
Max. Cos ϕ	Max. $\sum \text{Cos}\phi$	three-phase	✓	✓
Min. active power	Max. $\sum P_-$	three-phase	✓	✓
Min. reactive power	Max. $\sum Q_-$	three-phase	✓	✓
Min. cos ϕ	Max. $\sum \text{Cos}\phi_-$	three-phase	✓	✓
Dated load curve	$\sum P_+$	three-phase	n.a.	W
Energy consumption	Ea+ day, week, month, n and n-1	total	n.a.	kWh and 10Wh

Where $T_i = E_{a+}$ of tariff $i, i=1-4$; the tariff is selected by the communication bus.

n.a. = not available.

5. INSTALLATION

The paragraphs below describe how to install the device.

5.1. Recommendations and safety

Refer to the safety instructions (section "2. Hazards and warnings", page 4)

- Keep away from electromagnetic interference generator systems,
- Avoid vibrations with accelerations greater than 1 g for frequencies lower than 60 Hz.

5.2. DIN rail mounted

The DIRIS A14 unit (ref. 4825 0020) may be snapped onto a 35 mm DIN rail (EN 60715TM35). It must be used in electrical cabinets.

5.3. Door mounted

The DIRIS A14 unit (ref. 4825 0021) may be fitted onto a door with a 92x92 mm cutout.

Dimensions: *in/mm*

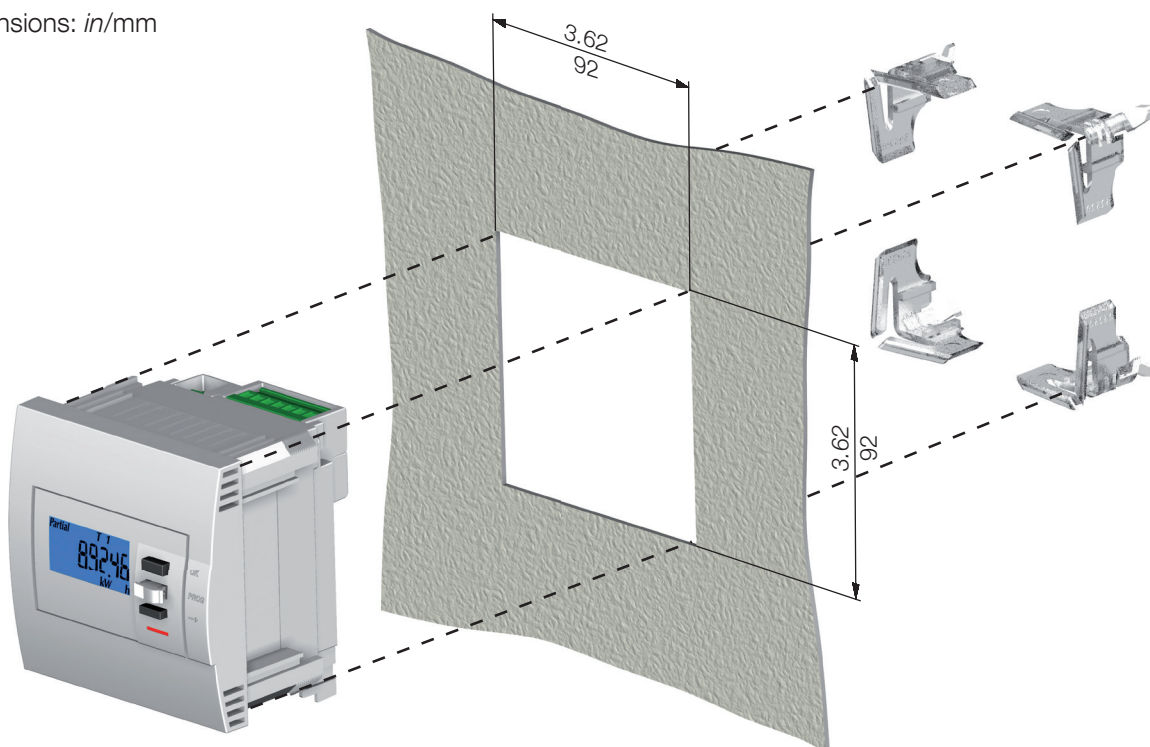

6. CONNECTION

6.1. DIRIS A14 connection - DIN rail mounted

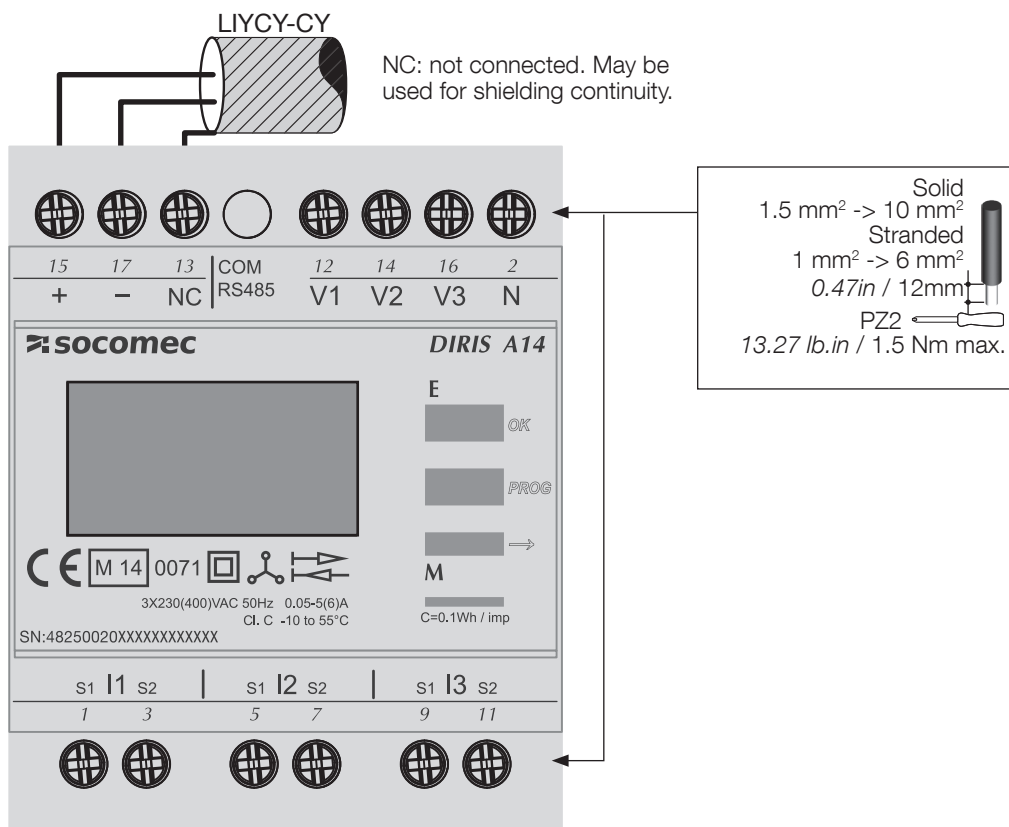

6.2. DIRIS A14 connection - door mounted

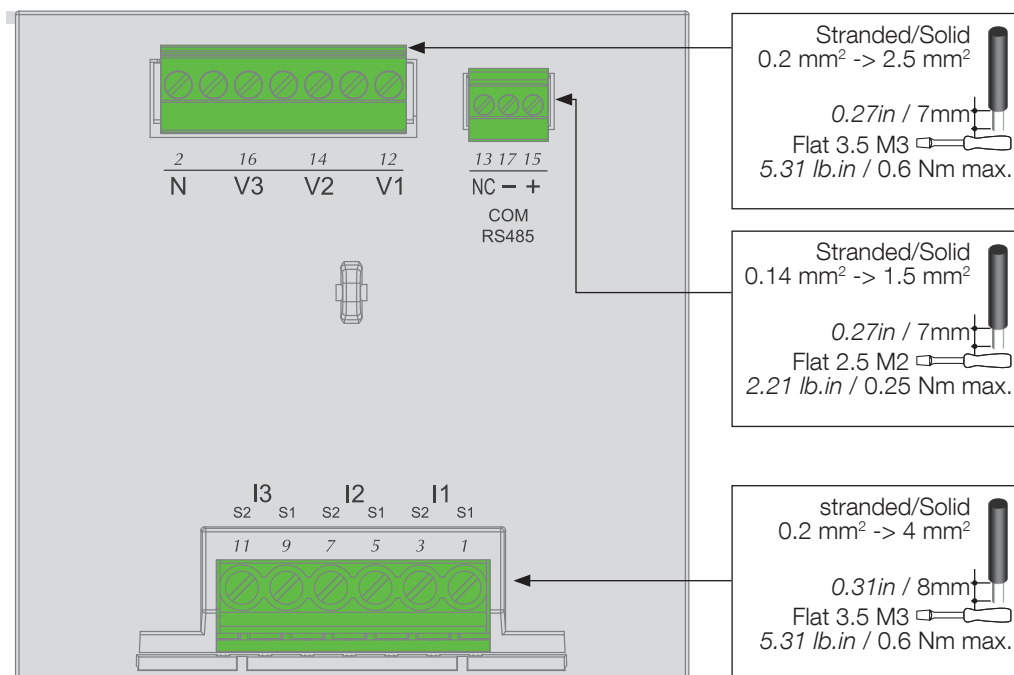

6.3. Connection to the electrical network and to the loads

The DIRIS A14 can be used on single-phase, two-phase or three-phase networks.

6.3.1. Configurable loads based on the network type

The table below summarises the loads that it is possible to configure depending on the type of network at the installation.

Network type	Configurable load
1P+N single-phase	1P+N – 1CT
2P two-phase	2P – 1CT
3P three-phase	3P – 3CT / 3P – 2CT / 3P – 1CT
3P+N three-phase	3P+N – 3CT / 3P+N – 1CT

6.3.2. Description of the main network and load combinations

Legend:

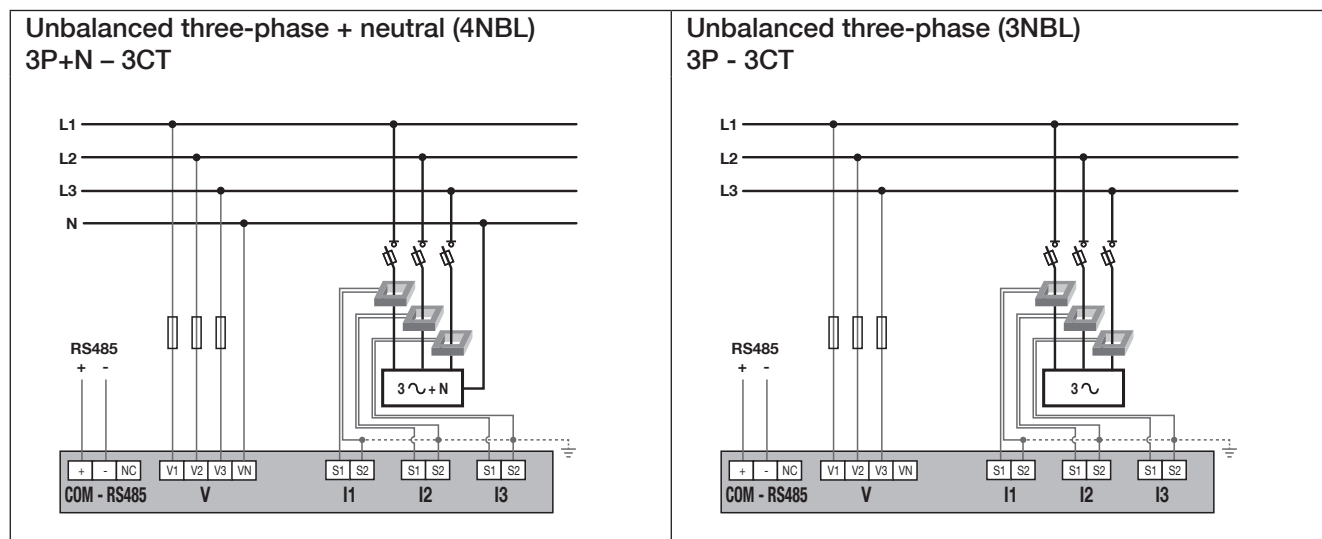
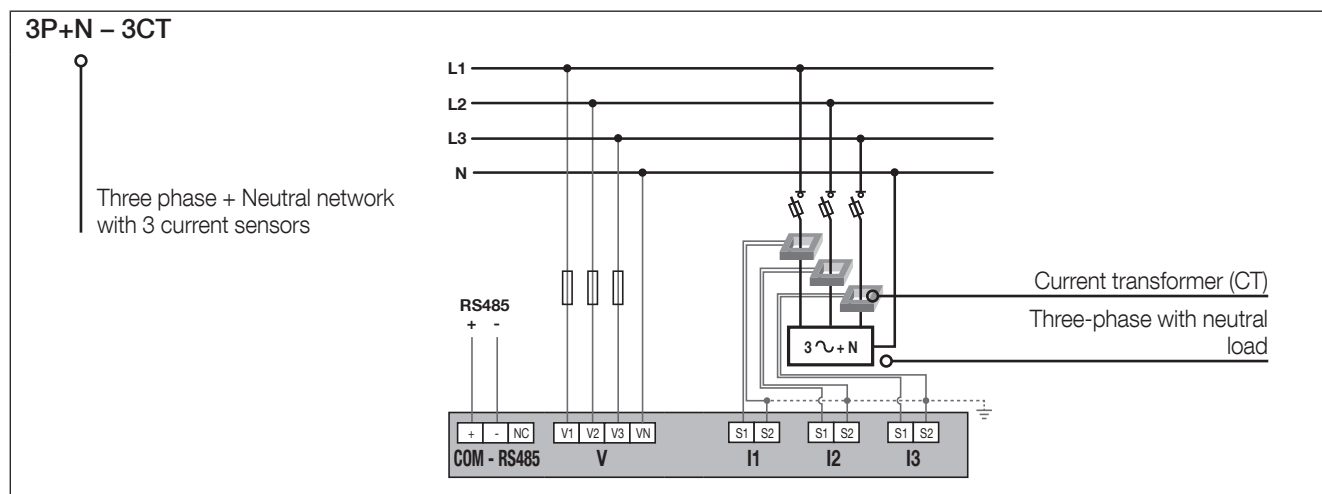

These 2 connections for the DIRIS A14 are MID-compliant in bidirectional mode.

**Unbalanced three-phase (3NBL)
3P - 2CT**

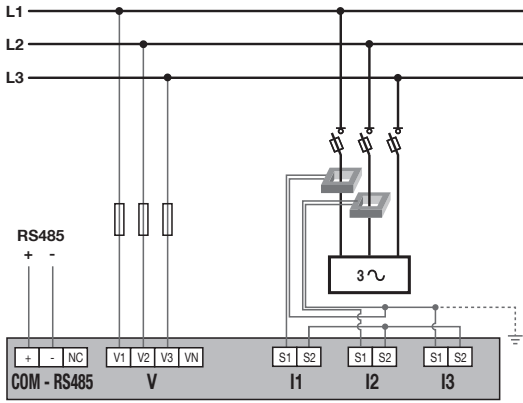

**Unbalanced three-phase (3NBL)
3P - 2CT**

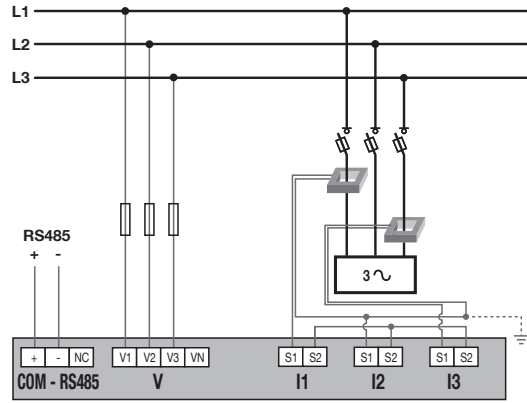

The 2CT solution reduces by 0.5% the accuracy of the phase for which the current is deduced by a vector calculation.

**Balanced three-phase + neutral (4BL)
3P+N - 1CT**

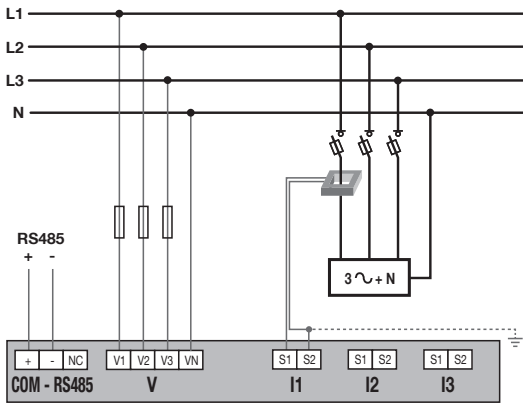

**Balanced three-phase (3BL)
3P - 1CT**

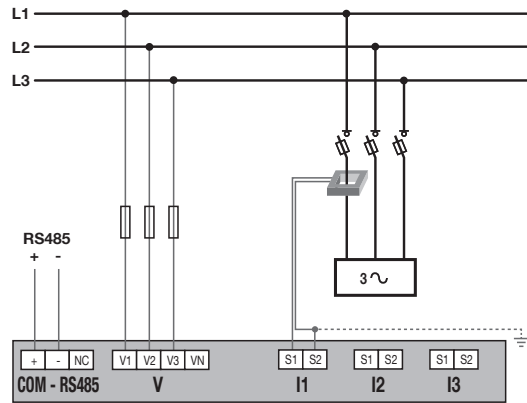

Balanced two-phase (2BL) 2P - 1CT

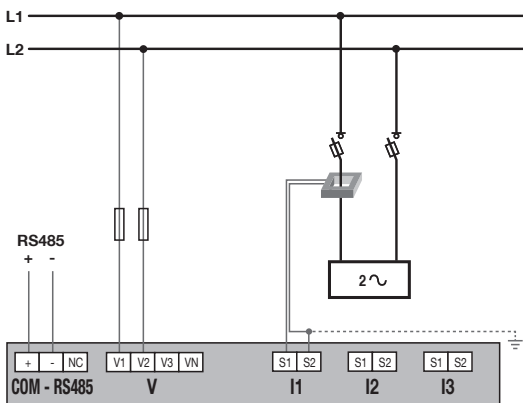

Single-phase (1BL) 1P+N - 1CT

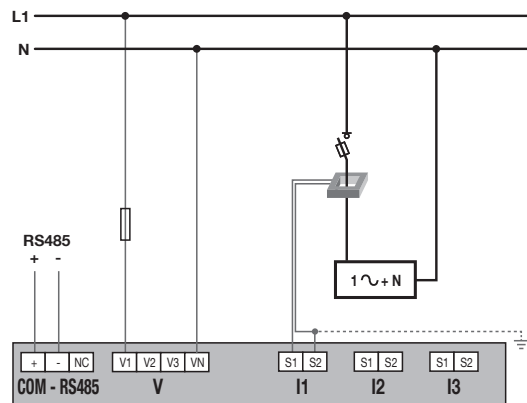

 Fuse: 0.5 A gG / 0.5 A class CC

This connection for the DIRIS A14 is MID-compliant in single-directional mode.

7. MID COMPLIANCE

The following points must be taken into consideration to ensure that the device is used in compliance with directive MID 2014/32/EU:

- **Type of network**

The DIRIS A14 meters comply with the MID directive for connection to networks: 3P+N – 3CT (4NBL), 3P – 3CT (3NBL) in bidirectionnal and 1P+N – 1CT (1BL) in single-directionnal (see "6.3. Connection to the electrical network and to the loads", page 10)

- **Fitting terminal covers**

After connecting the product, ensure that the terminal covers are fitted properly and secured by the plastic seals provided with the product.

- **Locking the programming button**

Close the button cap by securing it with a seal

- **RS485 communication**

The information provided via the RS485 COM is transmitted for information only and has no legal value.

- **Declaration of MID conformity**

The MID declaration of conformity is available on the website: www.socomec.com/en/diris-a14

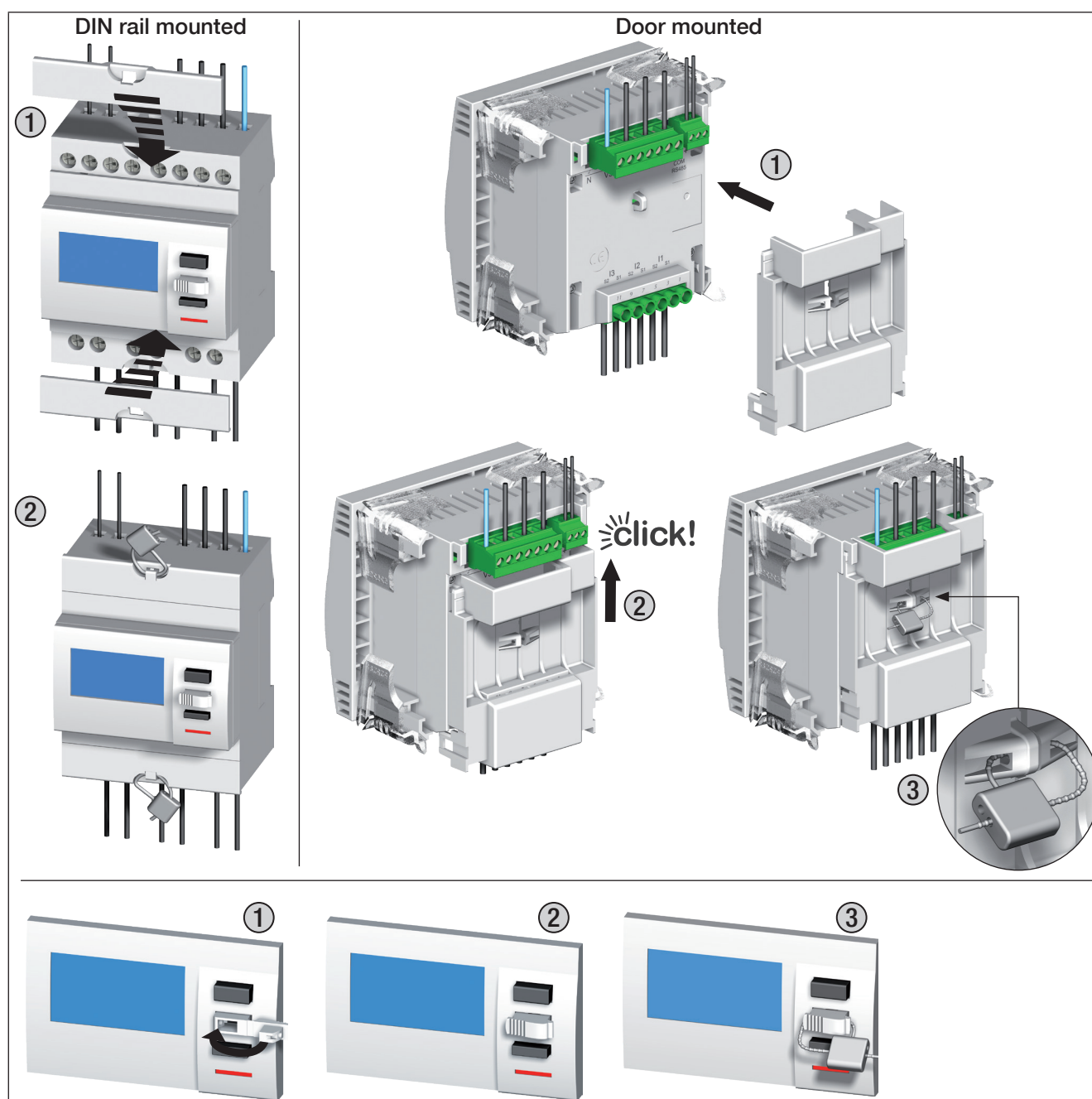

Back cover dismantling (if necessary)

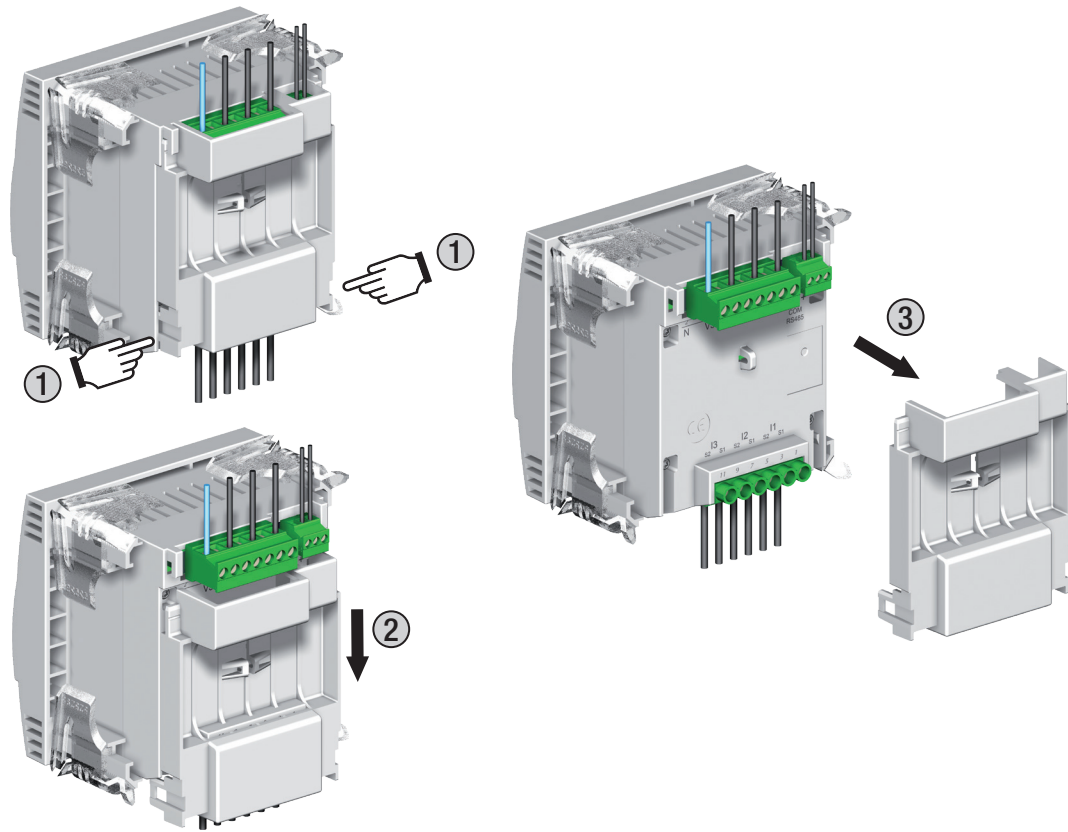

8. COMMUNICATION

8.1. General information

The modbus available on the DIRIS A14 communicates via an RS485 series link (2 or 3 wires) which is used to operate products from a PC or an API.
In a standard configuration an RS485 connection is used to connect 32 products to a PC or a controller over 1200 meters.

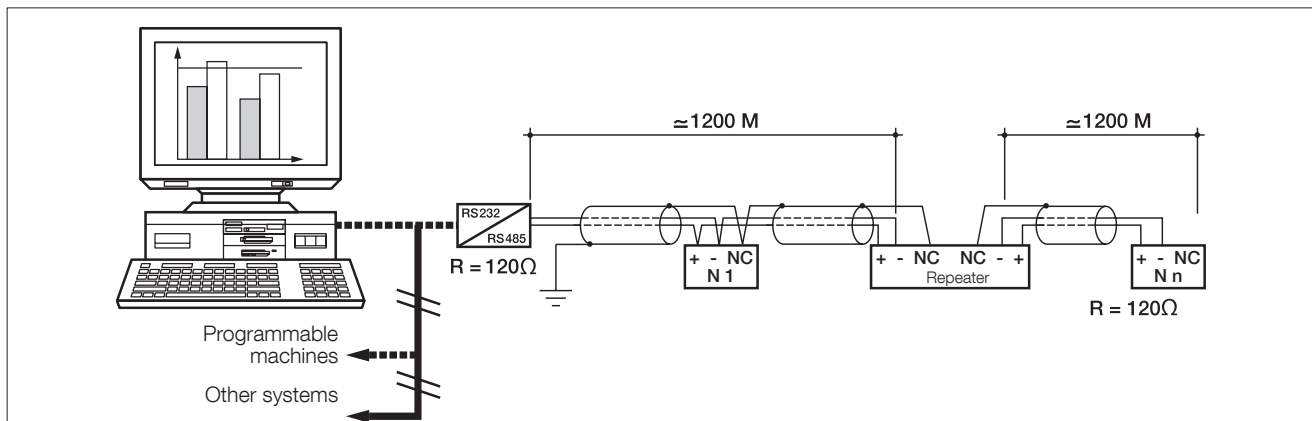
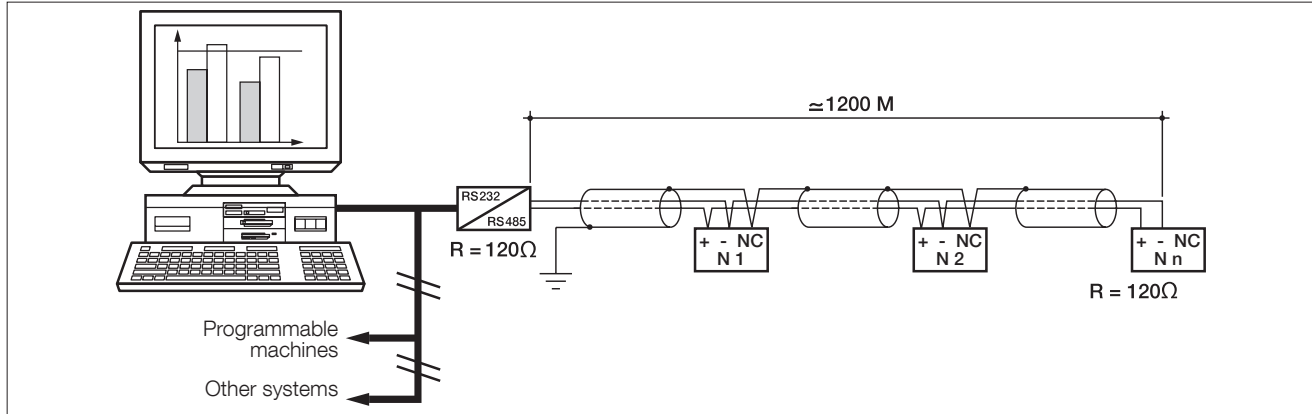

8.2. RS485 rules

A LIYCY shielded twisted pair must be used. We recommend using a shielded twisted pair with a general LIYCY-CY shielding in an environment where there is interference or in a very long network with a number of products.
If the distance of 1200 m is exceeded and/or the number of products is greater than 32, a repeater must be added to enable additional products to be connected.
A 120 Ohm resistor must be fixed at both ends of the connection.

8.3. Communication structure

The product communicates via a modbus protocol which involves a dialogue in accordance with a master/slave structure. The communication mode is the RTU (Remote Terminal Unit) mode with hexadecimal characters composed of at least 8 bits.

Modbus frame structure (master -> slave question):

Slave address	Function code	Address	Number of words to be read	CRC 16
1 byte	1 byte	2 bytes	2 bytes	2 bytes

To comply with the modbus protocol, the inter-character time must be ≤ 3 silences.

This means the time for 3 characters to be emitted so that the message is processed by the DIRIS A14.

In order to use the information correctly, you must use the modbus functions in accordance with the codes:

- 3: to read n words (maximum 128).
- 6: to write one word.
- 16: to write n words (maximum 128).

N.B.:

1 word \Leftrightarrow 2 bytes \Leftrightarrow 16 bits

2 words \Leftrightarrow 4 bytes \Leftrightarrow 32 bits

By selecting the slave address 0, a message is transmitted to all the devices on the network (only for functions 6 and 16).

Note: The response time (question/ response time out) is no more than 250 ms.

8.4. Communication tables

The communication tables and the associated explanations are available on the DIRIS A14 documentation page on the website at the following address:

www.socomec.com/en/diris-a14

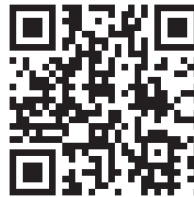



9. CONFIGURATION

The device can be configured by the Easy Config configuration software or directly from the DIRIS A 14 screen using the programming mode. The paragraphs below describe configuring using the screen.

9.1. Configuring using the screen

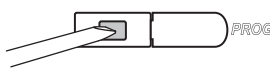
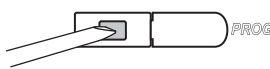
On the screen, the programming mode is used to modify parameters, such as the type of network, current transformers or communication parameters. How to browse through the programming mode is described in the following stages:

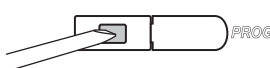
	Go to programming mode (using a screwdriver, press PROG for 3 seconds)
	Go to the next menu (press PROG once)
	Modifies the current screen parameters
	Validates the modification
	Exit programming mode (press PROG for 3 seconds)

 Note: after 120 seconds of inactivity, the device exits programming mode without saving the changes (except for a reset).

9.1.1. Example: configuring the choice of current transformer

In programming mode (see page 16), go to the "Current Transformer - CT" screen.

Example: changing the transformation ratio to 800/5.

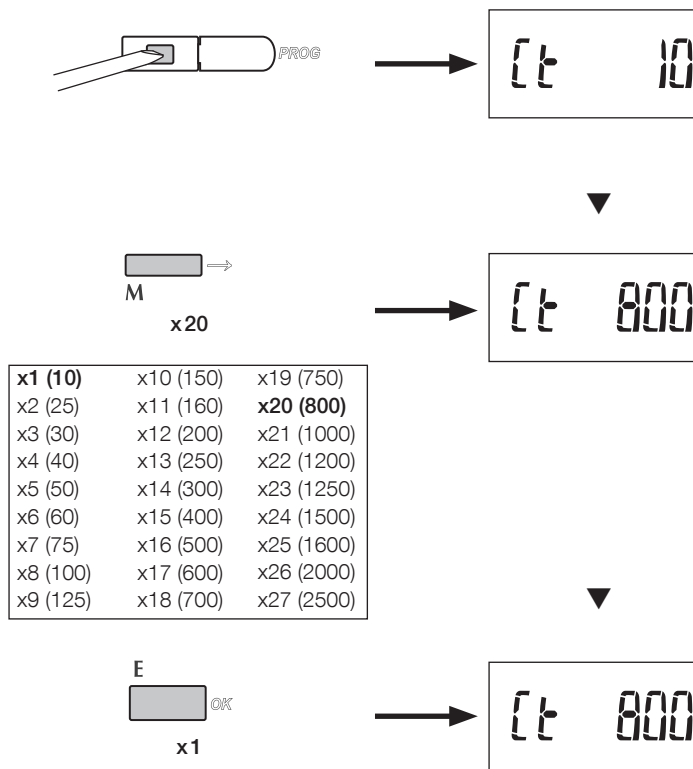

XX = default value

9.1.2. Overall view of the programming menu

Press PROG for 3 seconds and the device will go to programming mode.

The different screens can be accessed by pressing "PROG":

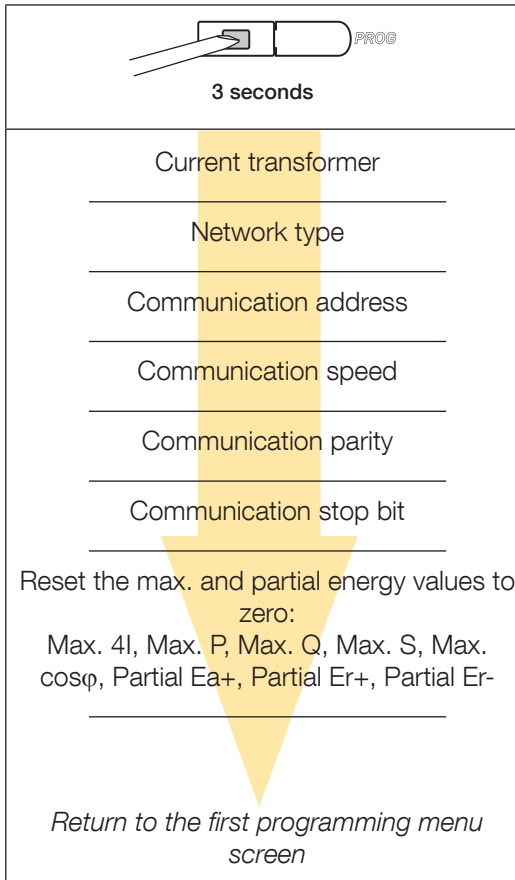

9.1.3. Detailed view of the programming menu



Current transformer	
ct 10	10, 25, ..., 2000, 2500A

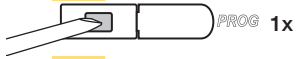

Network type	
net 4nbl	1BL, 2BL, 3BL, 3NBL, 4BL, 4NBL

Communication address	
Add 5	1, 2, ... 5 , ..., 253, 254

Communication speed	
bd 9600	4800, 9600 , 19200, 38400

Communication parity	
Par no	no, odd, even

Communication stop bit	
Stop 1	1, 2



Reset energies	
rst ^{MAX} 41	Max. 4I , Max. P, Max. Q, Max. S, Max. cosφ, Partial Ea+, Partial Er+, Partial Ea-, Partial Er-

Return to the first programming menu screen

XX = default value

10. USE

The electric dimensions can be accessed using the dedicated buttons: "Energy" and "Measurement". All the measurements relating to the button scroll down when you keep pressing the appropriate button. The available measurements are described in the table below:

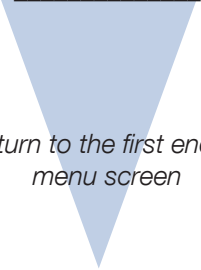
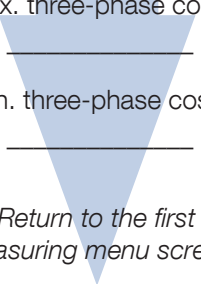
Energy	Measurement
	
Total imported active and reactive energy <hr/>	Instantaneous phase current <hr/>
Total exported active and reactive energy <hr/>	Max. phase current <hr/>
Partial imported active and reactive energy <hr/>	Instantaneous phase/phase voltages <hr/>
Partial exported active and reactive energy <hr/>	Instantaneous phase/neutral voltages <hr/>
 <p><i>Return to the first energy menu screen</i></p>	Frequency <hr/>
	Instantaneous three-phase active, reactive and apparent powers <hr/>
	Max. three-phase active, reactive and apparent powers <hr/>
	Min. three-phase active, reactive and apparent powers <hr/>
	Instantaneous three-phase $\cos\phi$ <hr/>
	Max. three-phase $\cos\phi$ <hr/>
	Min. three-phase $\cos\phi$ <hr/>
	 <p><i>Return to the first measuring menu screen</i></p>

10.1. Detailed view of the energy menu

E

OK

Total imported active energy	
$\Sigma T 1$ 9246 kW h	

Total imported reactive energy	
Σ 9246 k varh	

Total exported active energy	
Σ - 9246 kW h	

Total exported reactive energy	
Σ - 9246 k varh	

Partial imported active energy	
Partial $T 1$ 9246 kW h	

Partial imported reactive energy	
Partial 9246 k varh	

Partial exported active energy	
Partial - 9246 kW h	

Partial exported reactive energy	
Partial - 9246 k varh	

Return to the first energy menu screen

10.2. Detailed view of the measurement menu

M →

Instantaneous phase currents	
$L1$ 12345 A	(L1, L2, L3, LN)

Max. phase currents	
MAX $L1$ 201 k A	(L1, L2, L3, LN)

Instantaneous phase-phase voltages	
$L12$ 39278 V	(L1-2, L2-3, L1-3,)

Instantaneous phase-neutral voltages	
$L1$ 22675 V	(L1, L2, L3)

Frequency	
F 5003	

Instantaneous three-phase active power	
Σ 57923 kW	

Instantaneous three-phase reactive power	
Σ 57923 k var	

Instantaneous three-phase apparent power	
Σ 57923 kVA	

Max. three-phase active power	
MAX Σ 57923 kW	

Max. three-phase reactive power	
MAX Σ 57923 k var	

Max. three-phase apparent power	
MAX Σ 57923 kVA	

Min. three-phase active power	
MAX Σ - 57923 kW	

Min. three-phase reactive power	
MAX Σ - 57923 k var	

Instantaneous three-phase $\cos\phi$	
$\cos\phi$ 0.97	

Maximum positive $\cos\phi$ phase angle*	
MAX Σ $\cos\phi$ 0.99	

Maximum negative $\cos\phi$ phase angle*	
MAX Σ - $\cos\phi$ 0.99	

* worse $\cos\phi$ phase angle value is 0, best phase angle value is either 1 (positive) or -1 (negative)

Return to the first measuring menu screen

11. CONNECTION TEST FUNCTION

During the test the DIRIS must have current and voltage on each of the phases.

In addition, this function considers that the power factor (PF) of the installation is between $0.6 < PF < 1$. If the installation PF is not within this range this function cannot be used.

Starting the test

Press "E" for 3 seconds. The error message appears on the screen. If there is more than one error, they are displayed one after the other.

The messages below indicate the connection status of the phases on the DIRIS A14.

Message list	Networks involved
Err 0 = no errors	4NBL / 3NBL / 4BL / 3BL / 2BL / 1BL
Err 1 = CT connection inverted on phase 1	4NBL / 3NBL / 4BL / 3BL / 2BL / 1BL
Err 2 = CT connection inverted on phase 2	4NBL / 3NBL
Err 3 = CT connection inverted on phase 3	4NBL / 3NBL
Err 4 = I1 and I2 current inputs inverted	4NBL / 3NBL
Err 5 = I2 and I3 current inputs inverted	4NBL / 3NBL
Err 6 = I3 and I1 current inputs inverted	4NBL / 3NBL
Err 7 = voltage between V1 and V2 inverted	4NBL / 3NBL / 4BL / 3BL
Err 8 = voltage between V2 and V3 inverted	4NBL / 3NBL / 4BL / 3BL
Err 9 = voltage between V3 and V1 inverted	4NBL / 3NBL / 4BL / 3BL
Err 10 = voltage between V1 and N inverted	4NBL / 4BL
Err 11 = voltage between V2 and N inverted	4NBL / 4BL
Err 12 = voltage between V3 and N inverted	4NBL / 4BL
Err 13 = all V inputs are wrong	4NBL / 3NBL
Err 14 = all I inputs are wrong	4NBL / 3NBL
Err 15 = not enough current and/or voltage	4NBL / 3NBL / 4BL / 3BL / 2BL / 1BL

Connection errors must be corrected manually either by inverting the CT connections or by modifying the current or voltage connections including the neutral one.

Exiting the test

Press "E" for 3 seconds.

Example: CT connection inverted on 3 phases (4NBL network)

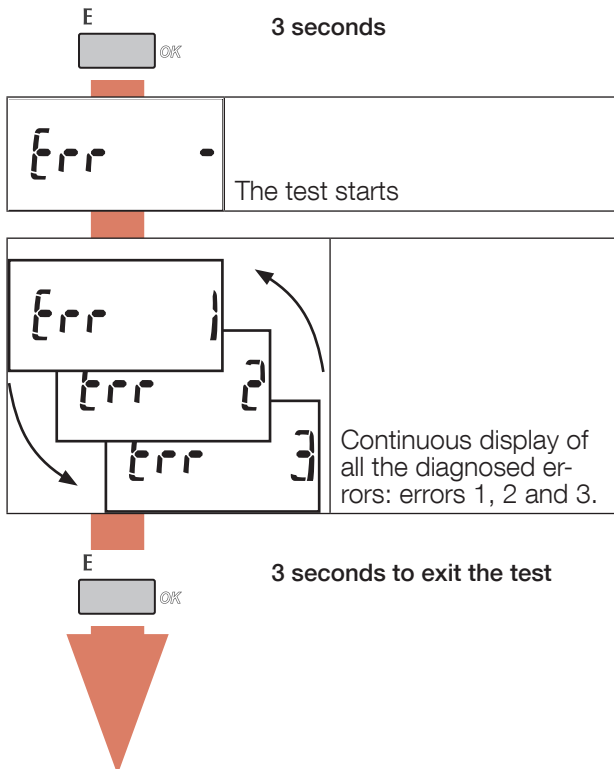

12. ASSISTANCE

CAUSES	SOLUTIONS
Device not working	Check the wiring of the plugs
Defective modbus communication	Check the RS485 modbus configuration: address, speed, parity, stop bit and recommended wiring (see "11. Connection test function", page 23)
"CRC Err" message displayed	The software has been corrupted. Please replace the device. Ensure that it is being used in compliance with the MID.
Voltages displayed = 0 V or incorrect	Check the connection. Start the connection test function (see "11. Connection test function", page 23).
Currents displayed = 0 A or incorrect	Check the connection. Start the connection test function (see "11. Connection test function", page 23).
Power levels and power factors (Cos ϕ) incorrect	Check the connection. Start the connection test function (see "11. Connection test function", page 23).

13. CHARACTERISTICS

GENERAL CHARACTERISTICS	
Compliant with	European EMC Directive No. 2014/30/EU dated 26/02/2014 LV Directive No. 2014/35/EU dated 26/02/2014 Measuring Instrument Directive MID No. 2014/32/EU dated 26/02/2014 EN50470-1/-3 IEC 61557-12 ⁽¹⁾ IEC 62053-23
Networks	Single-phase 2 wires 230V (1BL) / Two-phase 2 wires 400V (2BL) Three-phase 4 wires 3x230/400 V (4NBL) and three-phase 3 wires 3x230 V / 3x400 V (3NBL) ⁽²⁾
Management	Connection test
Frequency	50 and 60 Hz (± 1 Hz)
Power supply	Self-supplied
MEASURING CURRENTS (TRMS)	
Via CT with primary	up to 2500A
Via CT with secondary	5A
Measuring range on the secondary - Starting current (Ist) - Minimum current (Imin) - Transition current (Itr) - Reference current (Iref) - Permanent overload (Imax)	5 mA 50 mA 250 mA 5 A 6 A
Input consumption	< 0.2VA per phase
Measurement refresh period	1s
Accuracy	0.2%
Temporary overload on the secondary	120A for 0.5s
MEASURING VOLTAGES (TRMS)	
Direct measurement between phases	90 ... 460VAC
Direct measurement between phase and neutral	90 ... 265VAC
Input consumption	< 2VA per voltage circuit
Measurement refresh period	1s
Accuracy	0.2%
Permanent overload	480VAC
FREQUENCY MEASUREMENT	
Frequency measurement (range, resolution)	45 ... 65 Hz, 10mHz
POWER MEASUREMENTS	
Measurement range	10 W/VA/var ... 2 MW/MVA/Mvar
Active power accuracy	0.5%
Reactive power accuracy	2%
Apparent power accuracy	1%
Measurement updating period	1s
COS ϕ POWER FACTOR MEASUREMENT	
Measurement range	± 0.01 ... ± 1
Accuracy	1%
Measurement refresh period	1s
ENERGY MEASUREMENT	
Active	Yes
Reactive	Yes
Total and partial reading	Yes (0.01 ... 99999.99 kWh / MWh / kvarh / Mvarh)
MID reading	Single-directional in single-phase / Bidirectional in three-phase
Resolution	10 Wh, 10 varh

ENERGY ACCURACY	
Ea+, Ea- active energy (3NBL)	Class C (EN 50470-3)
Ea+ active energy (1NBL)	Class C (EN 50470-3)
Er+, Er- reactive energy	Class 2 (CEI 62053-23)
TARIFF FOR EA+⁽²⁾	
Tariff management	Yes
Number of tariffs managed	4
Tariff input	No
METROLOGICAL LED (EA+, EA-)	
Pulse value	10000 pulses / kWh
Colour	Red
DISPLAY	
Type	7 digit LCD with blue backlight
Refresh time	1 s
Backlight activation time	30 s
COMMUNICATION	
RS485	2 wires + shielding/ half duplex
Protocol	Modbus, RTU mode
Baudrate	4800 / 9600 / 19200 / 38400 Baud
Galvanic isolation	4 kV 1 min 50Hz
SAVING	
Energy registers	In the EEPROM memory
Clock	Battery operated
Load curve ⁽³⁾	In FRAM memory
ENVIRONMENTAL CONDITIONS	
Mechanical environment	M1
Electromagnetic environment	E2
Operating temperature range	- 10 °C ... + 55 °C
Storage temperature range	- 20 °C ... + 70 °C
Humidity	95% RH non-condensing
Installation	internal (box/cabinet)
DIRIS A14 HOUSING	
Dimensions W x H x D (mm)	Modular - width 4 modules (DIN 43880) 72 x 90 x 64 (ref. 4825 0020) 96 x 96 x 69.5 (ref. 4825 0021)
Mounting	On DIN rail (EN 60715) (ref. 4825 0020) On door (ref. 4825 0021)
Connection capacity, tightening torque	See chapter "6. Connection", page 9
Protection index	Front: IP51 - casing: IP20
Insulation class	Class II (EN 50470-1)
Weight	240 g (ref. 4825 0020) 450 g (ref. 4825 0021)

(1) Measures compliance.

(2) Voltages must be balanced in a 3NBL network.

(3) Functions only available via the communication system. The full list of these functions is set out in the modbus communication table which can be downloaded from the website at www.socomec.com.

14. PERFORMANCE CLASSES

The performance classes are drawn up in compliance with IEC 61557-12 Edition 1 (08/2007)

PMD classification	SD
Temperature	K55

14.1. Specification of the characteristics

SYMBOL	FUNCTION	PMD PERFORMANCE CLASS IN COMPLIANCE WITH IEC 61557-12	MEASUREMENT RANGE (IN = 5 A)
Pa	Total active power	0.5	1% ... 120% In
Q _V	Total reactive power (vector)	2	2% ... 120% In
S _V	Total apparent power (vector)	1	2% ... 120% In
E _a +/-	Total imported/ exported active energy	0.5	1% ... 120% In
E _{rA} +/-	Total imported/ exported reactive energy (vector)	2	2% ... 120% In
f	Frequency	0.1	45 ... 65 Hz
I	Phase current	0.2	10% ... 120% In
INc	Calculated neutral current	0.5	10% ... 120% In
U	Voltage (Lp-Lg or Lp-N)	0.2	50 ... 265 VAC Ph/N
PF _V *	Power factor (vector)	0.5	0.5 lagging to 0.8 leading
THDu*	Total harmonic voltage distortion rate (compared with the fundamental rate)	1	Fn=50Hz - rows 1 - 63 Fn=60Hz - rows 1 - 52
THDi*	Total harmonic current distortion rate (compared with the fundamental rate)	1	Fn=50Hz - rows 1 - 63 Fn=60Hz - rows 1 - 52

15. LIST OF ABBREVIATIONS

nEt	Type of network
4NBL	Unbalanced three-phase network, 4 wires with 3 CTs (3P+N – 3CT)
4BL	Balanced three-phase network, 4 wires with 1 CT (3P+N – 1CT)
3NBL	Unbalanced three-phase network, 3 wires with 2 or 3 CTs (3P – 3CT and 3P – 2CT)
3BL	Balanced three-phase network, 3 wires with 1 CT (3P – 1CT)
2BL	Balanced two-phase network, 2 wires with 1 CT (2P – 1CT)
1BL	Balanced single-phase network, 1 wire with 1 CT (1P+N – 1CT)
CT	Current transformer
MAX I	Maximum average values of phase currents
rST	Reset
MAX P, Q and S	Maximum value of average active, reactive and apparent powers
EA +/-	Imported/ exported active energy (kWh)
ER +/-	Imported/ exported reactive energy (kvarh)
THD I1, I2, I3	Harmonic current distortion rate
THD U12, U23, U31	Harmonic composed voltage distortion rate
THD V1, V2, V3	Harmonic phase-to-neutral voltage distortion rate
COM	Communication
Add	Slave address
bd	Communication speed in bauds (bits per second)
PAr	Communication frame parity
NO	No parity
Even	Even parity
Odd	Odd parity
Stop	Frame stop bit
1	1 stop bit
2	2 stop bits

CORPORATE HQ CONTACT:
SOCOMEC SAS
1-4 RUE DE WESTHOUSE
67235 BENFELD, FRANCE

www.socomec.com



542957C

 **socomec**
Innovative Power Solutions